

Electrical resistivity sounding and tomography

Electrical resistivity sounding has been in use since 1913 and went through major developments during the 1980s. Since 1990 the electrical imaging technique has also undergone major development. The two techniques differ in their approach and are suited to investigating different geological situations. Both rely upon the variability in electrical resistivity exhibited by earth materials and utilise an array of four electrodes implanted into the ground surface.

Electrical sounding

The commonest two arrays are the Wenner and the Schlumberger configurations. Current is passed through the ground *via* the outer ('C') electrodes and potential difference is measured between the inner pair ('P'). In the Wenner array the separation between each electrode (*a*) is equal. For the Schlumberger array, the distance between the two potential electrodes is small in comparison with that of the current electrodes. For the same current electrode separation, the Wenner array offers marginally improved resolution but a shallower depth of investigation over the Schlumberger array. For both array types, greater depth of investigation is achieved by increasing the separation of the current electrodes. The most common modern array is a modification of the Wenner, called the Offset Wenner. This is preferred as it improves data quality by being less sensitive to near-surface inhomogeneities.

As the electrode separations are increased about a common survey point, data are acquired that indicate changes in the ground resistivity with depth. At each electrode separation a given current is applied *via* the current electrodes and the voltage across the potential electrodes is measured. Ohm's Law states that the electrical resistance of a circuit component (in Ohms, Ω) is equal to the ratio of the potential drop across the component (Volts), divided by the current passed through it (Amps). The resistance value resulting from this calculation is specific to the spacing of the electrodes; to obtain a unit value of *apparent resistivity* (ρ_a) the effects of electrode geometry are corrected using a standard *geometric factor*. The resultant resistivity value is an average of all the layer resistivities in the electrified volume of earth, hence it is termed *apparent*. A logarithmic sounding curve is produced by plotting each value of ρ_a against electrode spacing (Figure 1). Curves can be inverted by hand or using dedicated software (e.g. RESIX) to derive horizontally layered models of true resistivity and layer thickness. The true resistivity is a diagnostic physical property and can be used to differentiate between materials.

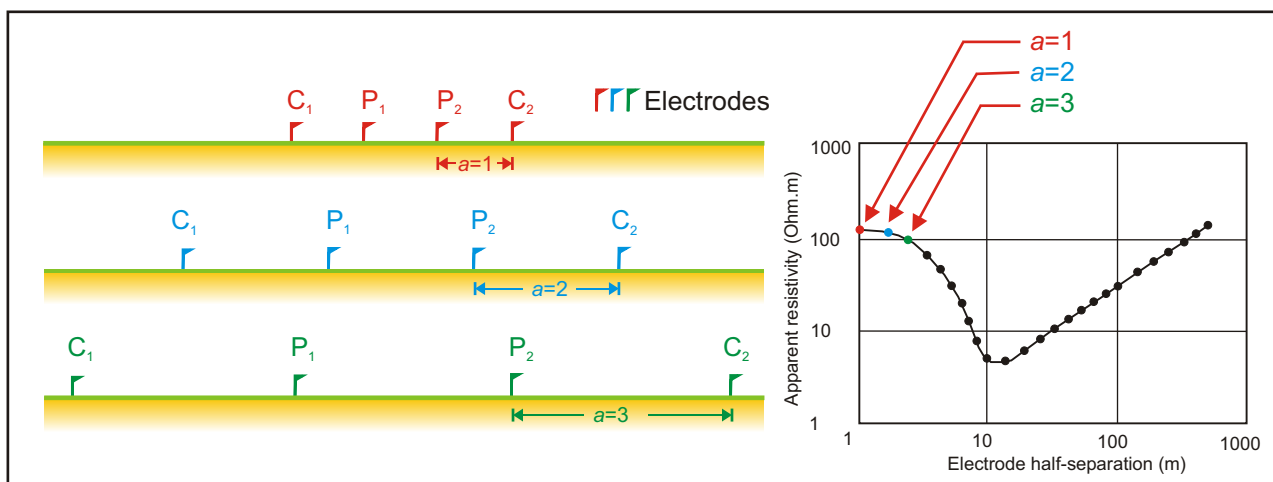

Figure 1: An expanding Wenner spread at electrode separations $a=1$, $a=2$ and $a=3$ (left) used to demonstrate the technique of electrical sounding. Acquisition of data at increasing electrode separations produces a log-log plot of apparent resistivity vs half-separation, termed a *sounding curve* (right). Data points acquired at the spacings shown on the left are presented in co-ordinated colours.

Electrical Resistivity Tomography (ERT/sub-surface imaging)

Often information on the lateral variability of ground properties is required. A simple electrical method of investigation is *constant separation traversing*, where an array of four electrodes is maintained at a fixed spacing and moved along the ground to provide information on resistivity at a single sounding depth. Using a Wenner array, the increment for such a traverse is typically equal to the electrode spacing (a). The results are plotted as a graph showing resistivity vs offset.

Repeating the traverse using increased electrode spacings (e.g. $2a$ then $3a$, etc.) adds additional layers of information to the graph and permits investigation of the vertical variation in ground properties (Figure 2). The *electrical tomography* technique requires collection of data at several multiples of a (commonly up to $16a$) to provide information at a range of depths, termed n levels. Each n level effectively corresponds to a constant separation traverse at a fixed multiple of a . Because the same electrode positions are occupied several times during acquisition of multiple traverses it is much faster to lay out an array of electrodes (typically 64 or more) connected by a multicore cable and use a computer to switch on the four electrodes required for each sounding. The computer can be set to run automatically through the required number of levels, performing noise checks and reacquiring bad data points to the operator's satisfaction. The resultant measured resistivity values are inverted using specialist software to produce a resistivity section (Figure 3).

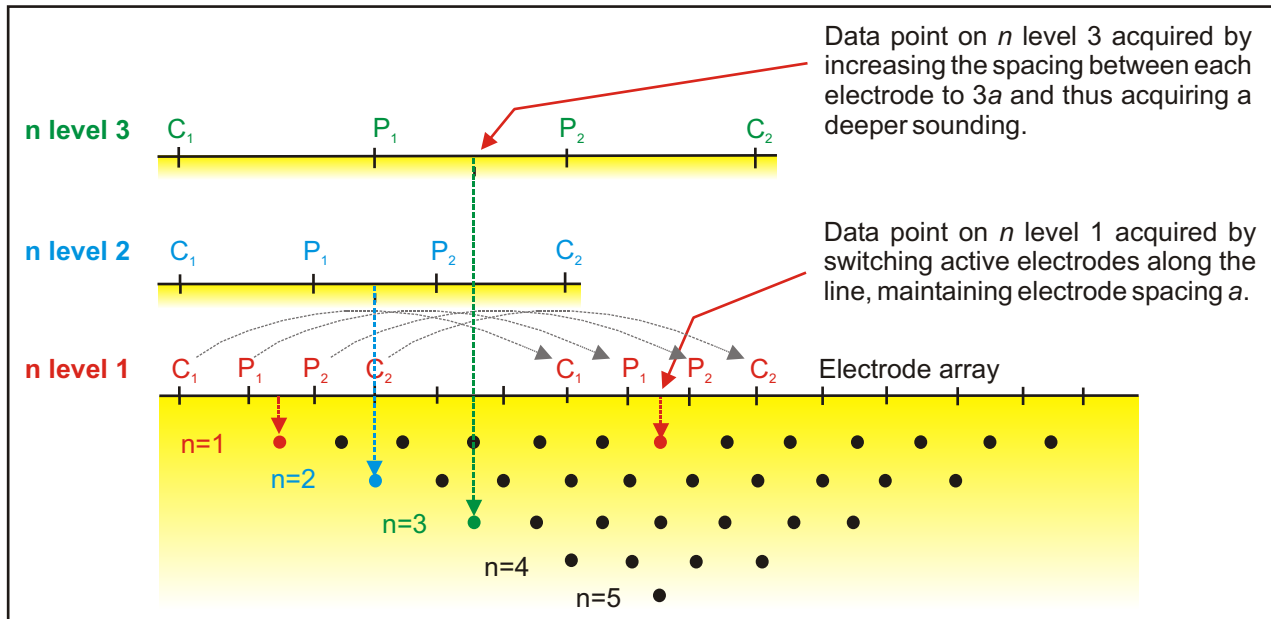

Figure 2: Example of data acquisition geometry during a 2D electrical tomographic survey, showing how increasing electrode spacing facilitates study of deeper ground materials.

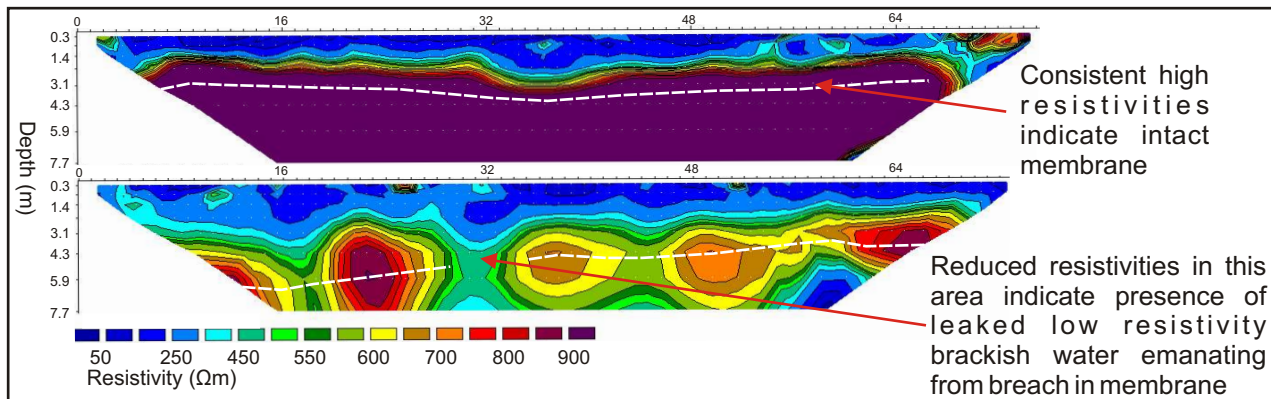

Figure 3: Example 2D resistivity model produced through inversion of electrical tomographic data showing (top) an intact geo-membrane and (bottom) a punctured geomembrane.